



HAL
open science

Domain decomposition for 3D nonlinear magnetostatic problems: Newton-Krylov-Schur vs. Schur-Newton-Krylov methods

Mohamed Ghenai, Ronan Perrussel, Olivier Chadebec, Frédéric Vi,
Jean-Michel Guichon, Gérard Meunier, Jonathan Siau

► To cite this version:

Mohamed Ghenai, Ronan Perrussel, Olivier Chadebec, Frédéric Vi, Jean-Michel Guichon, et al.. Domain decomposition for 3D nonlinear magnetostatic problems: Newton-Krylov-Schur vs. Schur-Newton-Krylov methods. 24th International Conference on the Computation of Electromagnetic Fields (Compumag'2023), May 2023, Kyoto, Japan. hal-04115574

HAL Id: hal-04115574

<https://cnrs.hal.science/hal-04115574>

Submitted on 2 Jun 2023

HAL is a multi-disciplinary open access archive for the deposit and dissemination of scientific research documents, whether they are published or not. The documents may come from teaching and research institutions in France or abroad, or from public or private research centers.

L'archive ouverte pluridisciplinaire **HAL**, est destinée au dépôt et à la diffusion de documents scientifiques de niveau recherche, publiés ou non, émanant des établissements d'enseignement et de recherche français ou étrangers, des laboratoires publics ou privés.

Domain decomposition for 3D nonlinear magnetostatic problems: Newton-Krylov-Schur vs. Schur-Newton-Krylov methods

Mohamed I. Ghenai^{1,2,3}, Ronan Perrussel², Olivier Chadebec¹, Frédéric Vi³,
Jean-Michel Guichon¹, Gérard Meunier¹, and Jonathan Siau³

¹Univ. Grenoble Alpes, CNRS, Grenoble INP, G2ELab, F-38000, Grenoble, France

²LAPLACE, Université de Toulouse, CNRS, INPT, UPS, Toulouse, France

³Altair Engineering, Meylan, France

Domain decomposition is a strategy designed to be used on parallel machines. This strategy leads to hybrid methods between direct and iterative solvers and allows users to benefit from the advantages of both. Lately, the growing size of simulations in electromagnetics brought to light the interest of using domain decomposition. Nonlinearity is also one of the problems specificities where the need for an efficient solver is high. This paper provides a comparison between two techniques of domain decomposition for solving 3D nonlinear magnetostatic problems. A test case illustrates the results that can be expected.

Index Terms—Domain decomposition, FETI method, Nonlinear magnetostatic, Parallel computing.

I. INTRODUCTION

DOMAIN decomposition is a strategy that seeks to decompose the problem into subdomains in order to be able to process them independently by relying on parallelization. Each subdomain will thus have its own local system to solve and will rely on solving methods adapted to its specificities (size, matrix properties...). For the case of nonlinear problems, most of the time, the nonlinearity is localized. This enables the domain decomposition method to distribute the workload resulting from the nonlinearity on some subdomains and have linear subdomains, where no need to calculate the tangent operator at each Newton-Raphson step. Hence, a local nonlinear solution can be performed on smaller problems instead of solving a much bigger global problem, while executing the full simulation in parallel. The originality of this paper is to provide a comparison between two non-overlapping domain decomposition techniques developed initially to treat nonlinear mechanics simulations. This paper details the implementation of these methods and shows an application of its use on a 3D contactor with nonlinear ferromagnetic materials.

II. PROBLEM DESCRIPTION

A 3D magnetostatic problem using a scalar potential formulation will be considered in the reminder of this paper [1]. Using the finite element method, for a domain Ω with a magnet as source, ferromagnetic materials and the device surrounded by air, the system to be solved is written as

$$K(u)u = b(u), \quad (1)$$

where

- $K(u)$ is the finite element matrix of the magnetic scalar potential formulation,
- u contains the values of the scalar potential at each node of the mesh,
- $b(u)$ is the source vector.

The Newton-Raphson iterative method is usually considered to solve (1). This method consists of computing the tangent

matrix DK as well as the residual r_u at every iteration n and solving successive linear systems of the form

$$DK(u^n)\delta u^n = -r_u(u^n). \quad (2)$$

The residual is given by $r_u(u^n) = K(u^n)u^n - b(u^n)$.

III. DOMAIN DECOMPOSITION

For this study, we consider non-overlapping domain decomposition methods. They are characterized by the absence of a shared surface (2D) or volume (3D) connecting neighboring subdomains [2]. This choice was motivated by the parallel computing capabilities that it offers.

A. FETI : Finite Element Tearing and Intconnecting

This method was introduced by Farhat and Roux in 1991 [3]. The domain is decomposed into subdomains and each subdomain is processed independently on a processor. The subdomain problems are usually solved by a direct solver, while an iterative method enables to solve a global problem condensed on the interface between subdomains. With the use of a proper preconditionner, it has been shown that the FETI method is optimal for a scalar diffusion problem[4].

If the domain Ω is decomposed into N_{sd} subdomains, on a subdomain s , a Poisson type problem has to be solved

$$K_s u_s = b_s + B_s^t \lambda, \quad (3)$$

where K_s , u_s , and b_s are respectively matrix, solution and right-hand-side relative to subdomain s , B_s is the signed Boolean matrix that extract from the vector u_s its signed restriction to the subdomain interface shared with its neighbors (opposite signs between two neighboring subdomains) and λ is the Lagrange multiplier vector required to enforce the continuity conditions (4) for all couples of neighbors,

$$\sum_{s=1}^{N_{sd}} B_s u_s = 0. \quad (4)$$

Floating subdomains need also to be defined. They are subdomains without Dirichlet-type boundary conditions: the pseudo inverse matrix K^+ is then used instead of the inverse K^{-1} . The bases of the kernel of each matrix K_s are concatenated in the rigid body mode matrix R . For a scalar problem the kernel of K_s is at most of dimension 1. R^i is the restriction of R on the interface. The problem condensed on the global interface between subdomains can then be written as

$$\begin{pmatrix} F^i & R^i \\ (R^i)^t & 0 \end{pmatrix} \begin{pmatrix} \lambda \\ \alpha \end{pmatrix} = \begin{pmatrix} -\sum_{s=1}^{N_{sd}} B_s K_s^+ b_s \\ R^t b \end{pmatrix}, \quad (5)$$

where α is of size the number of floating subdomains and

$$F^i = \sum_{s=1}^{N_{sd}} B_s K_s^+ B_s^t. \quad (6)$$

B. Newton-Krylov-Schur methods

The Newton-Krylov-Schur (NKS) methods can be implemented straightforwardly: at each Newton-Raphson iteration, the FETI method is considered to solve the tangent linear system (2). As in FETI, the Schur complement in NKS describes the interface problem. The global problem is never assembled and the residual computation is partitioned on the subdomains [5].

C. Schur-Newton-Krylov

The Schur-Newton-Krylov (SNK) methods were developed based on the observation that NKS methods do not take advantage of domain decomposition to solve the nonlinear problem, but only to solve the resulting tangent linear systems. In SNK methods the global nonlinear problem is decomposed into small nonlinear problems with continuity conditions imposed on the interface unknowns across the subdomains, resulting in a condensed nonlinear interface problem with tangent system

$$\begin{pmatrix} DF^i & R^i \\ (R^i)^t & 0 \end{pmatrix} \begin{pmatrix} \delta\lambda \\ \delta\alpha \end{pmatrix} = \begin{pmatrix} -r_\lambda \\ 0 \end{pmatrix}. \quad (7)$$

Problem (7), just as (6), is solved using a preconditioned conjugate projected gradient (PCPG) algorithm as in [3]. The algorithm of SNK methods is summarized in Algorithm 1.

IV. APPLICATION

Both NKS and SNK algorithms have been implemented in Altair FluxTM software [6]. They have been tested and compared to the standard Newton-Raphson method commonly used for this type of simulations. The linear solver used in Newton Raphson by default is a direct solver (LU factorisation). The test case is illustrated in Fig. 1 and represents a 3D magnetic contactor. It was decomposed into 4 subdomains: 1 air (linear), 2 upper pallet (nonlinear), 3 magnet (linear) and 4 E shape (nonlinear). The size of the test case is 2432 nodes.

Table I sums up the results. An adaptive convergence criteria has been used to obtain less PCPG iterations with a Dirichlet preconditioner [4]. The project was solved using 4 cores.

Algorithm 1 SNK with FETI algorithm

Require: $n = 1, \lambda^0 = R^i (R^{it} R^i)^{-1} R^t b$

while $\|\delta\lambda^n\| / \|\lambda^n\| \leq tol_g$ **do**

$K_s(u_s^n) = b_s(u_s^n) - B_s^t \lambda_s^n$ \triangleright Solve local NL problems

$p = 1; u_s^{n_1} = (R^i)^t \alpha_s^n$

while $\delta u \leq tol_{NR}$ **do**

Solve $DK_s(u_s^{n_p}) \delta^p u = b_s^p(u_s^{n_p}) - B_s^t \lambda_s^n$

$u_s^{n_{p+1}} \leftarrow u_s^{n_p} + \delta^p u$

$p \leftarrow p + 1$

end while

$r_\lambda^n \leftarrow \sum_{s=1}^{N_{sd}} B_s u_s^n$ \triangleright Compute residual

Solve FETI interface problem with PCPG

$\lambda^{n+1} \leftarrow \lambda^n + \delta\lambda^n$

$\alpha^{n+1} \leftarrow \alpha^n + ((R^i)^t R^i)^{-1} (R^i)^t (-DF^i(\lambda^n) \delta\lambda^n - r_\lambda^n)$

$n \leftarrow n + 1$

end while

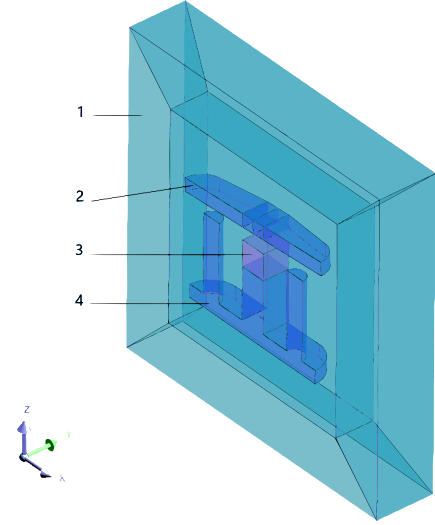

Fig. 1. Contactor test case with nonlinear materials.

TABLE I
RESULTS COMPARISON FOR THE CONTACTOR TEST CASE

Item	NR	NKS	SNK
Max local NL iterations	/	/	5
Global NL iterations	6	6	7
Speedup	1	1.3	0.4

REFERENCES

- [1] G. Meunier, ed., "The finite element method for electromagnetic modeling," John Wiley & Sons, 2010, pp. 69–83.
- [2] N. Spillane, "Méthodes de décomposition de domaine robustes pour les problèmes symétriques définis positifs," PhD thesis. Paris 6, 2014.
- [3] C. Farhat, and F. X. Roux, "A method of finite element tearing and interconnecting and its parallel solution algorithm," International journal for numerical methods in engineering 32 (1991), pp. 1205–1227.
- [4] C. Farhat, J. Mandel, and F. X. Roux, "Optimal convergence properties of the FETI domain decomposition method," Computer methods in applied mechanics and engineering 115 (1994), pp. 365–385.
- [5] J. Pebre, C. Rey, and P. Gosselet, "A nonlinear dual-domain decomposition method: Application to structural problems with damage," International Journal for Multiscale Computational Engineering 6.3 (2008).
- [6] Altair Engineering, "Altair FluxTM," <https://www.altair.com/flux>.