



HAL
open science

Reduced bases for model updating in structural dynamics based on constitutive relation error

Arnaud Deraemaeker, Pierre Ladevèze, Philippe Leconte

► **To cite this version:**

Arnaud Deraemaeker, Pierre Ladevèze, Philippe Leconte. Reduced bases for model updating in structural dynamics based on constitutive relation error. *Computer Methods in Applied Mechanics and Engineering*, 2002, 191 (21-22), pp.2427-2444. 10.1016/S0045-7825(01)00421-2 . hal-04510486

HAL Id: hal-04510486

<https://cnrs.hal.science/hal-04510486>

Submitted on 6 May 2024

HAL is a multi-disciplinary open access archive for the deposit and dissemination of scientific research documents, whether they are published or not. The documents may come from teaching and research institutions in France or abroad, or from public or private research centers.

L'archive ouverte pluridisciplinaire **HAL**, est destinée au dépôt et à la diffusion de documents scientifiques de niveau recherche, publiés ou non, émanant des établissements d'enseignement et de recherche français ou étrangers, des laboratoires publics ou privés.

Reduced bases for model updating in structural dynamics based on constitutive relation error

A. Deraemaeker^a, P. Ladevèze^{a,*}, Ph. Leconte^b

^a *LMT—Cachan (ENS de Cachan, Université Paris 6, CNRS), 61 Avenue du Président Wilson, 94235 Cachan Cedex, France*

^b *THALES (Thomson CSF Optronique), rue Guynemer BP 55, 78283 Guyancourt Cedex, France*

This paper deals with the application of a model reduction method to the updating of models of industrial structures with many degrees of freedom. The updating method is based on the concept of constitutive relation error. This is an iterative method in which each iteration consists of a first step in which the most important errors in the model are localized and a second step in which these errors are corrected. The reduction method follows a classical approach in which we introduce a truncated modal basis to which the static responses associated with different excitations are added. The efficiency of the method is illustrated on one example of a finite element model containing 10,000 degrees of freedom. In the first part, we update the mass and stiffness properties of the model based on eigenmodes and eigenfrequencies. In the second part, the damping properties are updated based on the frequency response functions of the structure.

Keywords: Model updating; Reduced basis; Constitutive relation error; Structural dynamics

1. Introduction

The use of numerical simulations is becoming increasingly important in today's industrial applications. With the increase of computer power, the models used have attained a high degree of complexity. Even though computers can calculate the response of such structures for linear problems, iterative calculations are usually excessively expensive.

Despite the increasing use of simulations, experimental testing is still necessary in order to validate the hypotheses used for numerical models. Very often, the test data and numerical predictions are poorly correlated. This can be explained by the difficulty of modeling certain parts of the structures, such as joints, whose mechanical behavior is generally not very well known.

Whenever the correlation between test and calculations is unsatisfactory, model updating methods are used. The purpose of such methods is to minimize the distance between the test data and the model by modifying the numerical model. A state-of-the-art review of these methods can be found in [1]. The first

* Corresponding author. Tel.: +33-1-47-40-22-38; fax: +33-1-47-40-22-40.
E-mail address: ladeveze@lmt.ens-cachan.fr (P. Ladevèze).

model updating methods which appeared fall in the ‘direct method’ category in which corrections of the mass and stiffness matrices of the model were sought without taking into account the physical meaning of the modifications. Within this category, a first set of methods is based on the search for minimum norm corrections [2,3]. A second set of methods is closely related to control theory [4,5]. The main drawback of these methods is that the corrections usually lack physical meaning, so the models are often invalid when they are used in configurations different from those used for the updating process.

In order to maintain the physical meaning of the model, indirect or parametric methods have been developed. In these methods, the changes in the stiffness and mass matrices are based on variations of the physical parameters of the model. The approach consists of building a cost function which represents the correlation between the numerical model and the test data in terms of the physical parameters of the model. Several types of cost functions can be used. They can be classified into three categories. The first two categories are the input residuals [6,7] and the output residuals [8,9]. The third category is based on a residual called “constitutive relation error (CRE)”. The initial work on model updating goes back to the eighties [10]. The first development of the method was aimed at achieving model updating based on eigenfrequencies and eigenmodes [11]. Then, the method was extended to forced vibration problems in [12,13]. This approach is based on the so-called Drucker error and has proved its ability to update the mass, stiffness and damping properties [14]. The method can also deal with nonlinearities due to both the material and contact. The concept of dissipation error was introduced in a new development presented in [15]. This error has a clear mechanical meaning and emphasizes the dissipation properties of the model. Let us also note the development of very similar methods for the free vibration case, such as minimum dynamic residual expansion (MDRE) [16] and modeling error in the constitutive equations (MECE) [17].

The cost function to be minimized is generally nonlinear with respect to the model’s parameters. Thus, it is necessary to use an iterative procedure in order to update the model. The use of models with a large number of degrees of freedom makes these calculations very costly in terms of computer time (CPU). The knowledge of the excitations, the points of measurement and the possible variations in the structure enable one to define a subspace of basis vectors whose dimension is much smaller than the initial space. This approach has the advantage of reducing the cost of updating the model drastically. Among the existing approaches, we mention those based on sensitivity vectors (for a state-of-the-art review of these methods, see [18]), the multimodel approach [19] in which the basis is formed by the truncated modal bases of the model for different values of the model’s parameters and the approach presented in [20] in which the variation of the model’s parameters is interpreted as excitations applied to the initial structure. Let us also mention the existence of an iterative method to construct a solution with a given accuracy for the MDRE method [21].

The model updating method we use is based on the concept of CRE. The main idea in this method is to subdivide the equations and quantities into a reliable group and another which is less reliable. For the numerical model, it is assumed that the constitutive relations can be inaccurate, which leads to the construction of an error called CRE. This error can be calculated locally on the structure, which allows us to detect the regions which have not been modeled correctly. Regarding experimental data, the amplitudes of the measured data (force, displacement, ...) are considered to be the less reliable quantities which lead to the construction of an error on the measurements. The reliable equations and quantities are satisfied exactly, whereas the possible variations in the model are due only to the less reliable equations.

In order to reduce the cost associated with the calculation of the error, we first consider a truncated modal basis. We assume that damping is small, that the frequency considered in the calculation is small compared to the frequencies of the eigenmodes retained in the truncated modal basis and also that the variations in the model’s parameters are small. With these assumptions, we show that the calculation of the error can be treated as a forced vibration problem in which the excitations are associated with the less reliable equations and quantities. However, the excitations are functions of the solution of the problem. Therefore, following the approach described in [20], we seek a first-order approximation of these excitations.

Then, the initial truncated modal basis is enriched with the identified excitations by following a classical approach in which we add the Krylov vectors associated with these excitations. A localization step and a correction step must be performed at each iteration of the method. A different reduced basis must be used for each of these steps.

This paper is organized as follows: in the first part, we outline the model updating method based on CRE and we detail the discrete formulation of the problem for linear, damped structures. In the second part, we address the choice of the reduced basis. By rewriting the problem in order to express the error calculation on the model as a forced vibration problem, we identify the different types of excitations that need to be taken into account. Then, we propose a reduced basis which is a function of these excitations. In the last part, we illustrate the effectiveness of the method on a numerical example. The structure is a simplified model of camera equipment intended to be attached to an airplane. The finite element model has more than 10,000 degrees of freedom (dofs). We illustrate the capabilities of the reduction method based on modal data as well as frequency response functions (FRF). The basis for localization contains less than 100 vectors which are the low frequency modes to which static corrections to forces located at the sensors are added. For the correction step, static corrections associated to the variable parameters are added to the basis used for localization.

2. Presentation of the updating method

2.1. The reference problem

We consider a structure within a domain Ω during a time interval $[0, T]$ (Fig. 1). On the boundary $\partial\Omega$, displacements \underline{U}_d and forces \underline{F}_d are prescribed on $\partial_1\Omega$ and $\partial_2\Omega$ respectively. Body forces \underline{f}_d exist inside the domain Ω . The reference problem consists of finding the displacements $\underline{U}(\underline{M}, t)$, stresses $\sigma(\underline{M}, t)$ and forces $\underline{\Gamma}(\underline{M}, t)$, $t \in [0, T]$, $\underline{M} \in \Omega$ which verify a set of equations that we subdivide into a reliable group and a less reliable group:

The reliable equations:

- the equilibrium equations.

The less reliable equations:

- the constitutive relations.

In order to take into account both the free- and the forced-vibration cases, we will work in the frequency domain. In addition to the equations hereabove, we need some data in order to solve the problem

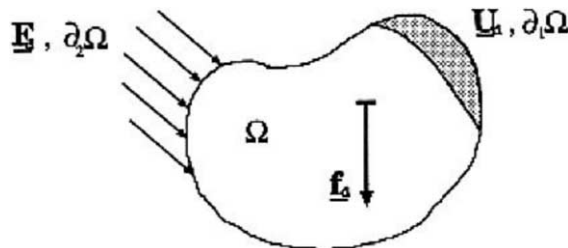

Fig. 1. Domain studied and applied loads.

(frequency, direction and amplitude of excitation, boundary conditions, ...). In the framework of model updating, this data come from measurements on a real structure. We consider for example a structure excited in one point on which the displacements are measured at different locations. In this example, we divide the data as follows:

The reliable measurements:

- the measured angular frequency ω ;
- the positions and directions of the excitation and sensors.

The less reliable measurements:

- the amplitudes of the forces $\tilde{\underline{F}}_d$ and displacement $\tilde{\underline{U}}_d$ at the points of excitation;
- the amplitudes of the displacements at the sensor points $\tilde{\underline{U}}_\omega$, which constitute a vector of finite dimension containing all discrete measurement values.

This separation is only given as an example and can vary depending on the problem. The reliable quantities and equations define the admissible solution. We seek a solution which is admissible and which verifies the less reliable equations and quantities as closely as possible. The problem we must solve is

$$(P_\omega) \quad \text{Find } s \in S_{\text{ad}}^\omega \quad \text{which minimizes } e_\omega^2(s') \text{ with } s' \in S_{\text{ad}}^\omega \quad (1)$$

where $e_\omega^2(s')$ is the modified CRE. In the case of a single excitation, the measured displacements are normed by the amplitude of the force vector so that only the amplitudes of the displacements appear in the expression of the modified error, which can be written at a given frequency as

$$e_\omega^2(s) = \xi_\omega^2(s) + \frac{r}{1-r} \|\Pi\{U\} - \tilde{\underline{U}}_\omega\|^2 \quad (2)$$

where $\xi_\omega^2(s)$ is the CRE and the second term represents the error on the measurements. $e_\omega^2(s)$ contains all the less reliable quantities and equations which are to be verified by the admissible solution as closely as possible.

Π is a projection operator which when applied to vector $\{U\}$ gives the value of the vector at the sensors. $\|\cdot\|^2$ is an energetic error measure equivalent to $\xi_\omega^2(s)$. The choice of this error measure will be addressed in Section 3.1. The coefficient $r/(1-r)$ is a weighting factor which allows us to assign a greater or lesser degree of confidence to the measurements: the value of r is close to 1 if the measurements are considered very reliable and close to 0 in the opposite case. The value currently used is 0.5.

In the case of multiple excitations, additional terms appear in the expression of $e_\omega^2(s)$ in order to take into account the fact that the amplitudes of the measured forces are not reliable quantities. For more details, see [22].

Remark. There are other examples where we could consider that the direction or the position of the excitation is not reliable. In that case, the definition of the modified CRE and the admissibility is thus changed according to this new assumption.

2.2. Modified constitutive relation error

We consider the following constitutive relations:

$$\sigma = \mathbf{H}\varepsilon + i\omega\mathbf{B}\varepsilon, \quad (3)$$

$$\underline{\Gamma} = -\rho\omega^2\underline{U} \quad (4)$$

where ρ is the density (assumed to be constant), \mathbf{H} and \mathbf{B} are the Hooke's and damping operators and ε represents the deformation tensor. From these two constitutive relations, it is possible to build the 'Drucker error' [23] which, for a given frequency (displacement formulation), is expressed as

$$\begin{aligned} \xi_\omega^2(\underline{U}, \underline{V}, \underline{W}) = & \int_{\Omega} \frac{\gamma}{2} \operatorname{tr}[(\mathbf{H} + T\omega^2\mathbf{B})(\varepsilon(\underline{V}) - \varepsilon(\underline{U}))^*(\varepsilon(\underline{V}) - \varepsilon(\underline{U}))] \\ & + \frac{1-\gamma}{2} \rho\omega^2(\underline{U} - \underline{W})^*(\underline{U} - \underline{W}) \, d\Omega \end{aligned} \quad (5)$$

where “*” represents the complex conjugate; we introduced fields \underline{U} , \underline{V} , \underline{W} such that

$$\underline{U}_c = \underline{U}, \quad (6)$$

$$\sigma_s = \mathbf{H}\varepsilon(\underline{V}) + i\omega\mathbf{B}\varepsilon(\underline{V}), \quad (7)$$

$$\underline{\Gamma}_s = -\rho\omega^2\underline{W}. \quad (8)$$

We also define the relative error

$$\xi_{\text{or}}^2 = \frac{\xi_\omega^2}{D_\omega^2} \quad (9)$$

with

$$D_\omega^2 = \int_{\Omega} \frac{\gamma}{2} \operatorname{tr}[(\mathbf{H} + T\omega^2\mathbf{B})\varepsilon(\underline{U})^*\varepsilon(\underline{U})] + \frac{1-\gamma}{2} \rho\omega^2\underline{U}^*\underline{U} \, d\Omega. \quad (10)$$

Assuming that the structure is divided into substructures $E \in \mathbf{E}$, the error can be viewed as the sum of the contributions of all substructures:

$$\xi_{\text{or}}^2(s) = \sum_{E \in \Omega} \xi_{E\omega}^2(s). \quad (11)$$

The relative error for each substructure is given by

$$\begin{aligned} \xi_{E\omega}^2 = & \frac{1}{D_\omega^2} \int_{\Omega_E} \frac{\gamma}{2} \operatorname{tr}[(\mathbf{H} + T\omega^2\mathbf{B})(\varepsilon(\underline{V}) - \varepsilon(\underline{U}))^*(\varepsilon(\underline{V}) - \varepsilon(\underline{U}))] \\ & + \frac{1-\gamma}{2} \rho\omega^2(\underline{U} - \underline{W})^*(\underline{U} - \underline{W}) \, d\Omega_E. \end{aligned} \quad (12)$$

When the structure is studied in a frequency range, we introduce a weighting factor $z(\omega)$ such that

$$\int_{\omega_{\min}}^{\omega_{\max}} z(\omega) \, d\omega = 1, \quad z(\omega) \geq 0. \quad (13)$$

The Drucker error in a frequency range is given by

$$\xi_T^2 = \int_{\omega_{\min}}^{\omega_{\max}} \xi_{\text{or}}^2 z(\omega) \, d\omega \quad (14)$$

and the local contributions become

$$\xi_{ET}^2 = \int_{\omega_{\min}}^{\omega_{\max}} \xi_{E\omega}^2 z(\omega) \, d\omega. \quad (15)$$

The modified CRE is now

$$e_T^2 = \int_{\omega_{\min}}^{\omega_{\max}} \frac{1}{D_\omega^2} e_\omega^2 z(\omega) d\omega. \quad (16)$$

The simplest choice for function $z(\omega)$ is

$$z(\omega) = \frac{1}{\omega_{\max} - \omega_{\min}}. \quad (17)$$

This function can be adjusted based on the regions of interest in the frequency range. The value of ξ_T^2 represents the relative quality (in %) of the numerical model with respect to the measurements.

2.3. Implementation of the updating method

2.3.1. Localization step

For each experimental frequency ω , we solve problem (P_ω) given by (1). The solution of this problem allows to calculate the indicators ξ_T^2 , ξ_{ET}^2 and e_T^2 defined in Section 2.2. The value of ξ_T^2 represents the relative quality (in %) of the numerical model with respect to the measurements in a certain frequency range. This allows us to decide whether model updating is necessary.

If model updating is considered necessary, we start from our mathematical model which depends on a number of uncertain parameters, such as Young's modulus or the thickness of certain parts. We arrange these structural parameters into a vector \underline{k} ; we call the corresponding space \mathbf{k} . The selection of the 'most erroneous' substructures is based on the criterion:

$$\xi_{ET}^2 \geq \delta \cdot \max_{E \in \mathbf{E}} \xi_{ET}^2 \quad (18)$$

with, for example, $\delta = 0.8$. Let us note that large errors in all substructures indicate that the error distribution is nearly uniform in the structure. Let \mathbf{Z} be the set of the substructures which verify (18).

2.3.2. Correction step

The localization step allows us to select the regions of the structure where the modeling error is large. Only parameters belonging to these substructures are selected for correction. The problem is: Find $\underline{k} \in \mathbf{k}_z$ which minimizes

$$\underline{k} \rightarrow J(\underline{k}), \quad (19)$$

$$\mathbf{k}_z \rightarrow R. \quad (20)$$

The functional $J(\underline{k})$ is defined by

$$J(\underline{k}) = \int_{\omega_{\min}}^{\omega_{\max}} \frac{1}{D_\omega^2} e_\omega^2 z(\omega) d\omega.$$

This is a nonlinear problem with respect to the parameters in \underline{k} . We solve it using a BFGS-based minimization algorithm. The gradients of the cost function are calculated numerically. Thus, the stiffness, mass and damping matrices are reassembled and problem P_ω is solved for each variation of the parameters.

2.3.3. Interruption of the model updating process

Once the correction has been made, the value of ξ_T^2 is reevaluated. If it falls below the required quality level ξ_0^2 , the updating process is terminated. If not, a new iteration consisting of a localization step and a

correction step is performed. In each iteration, new erroneous substructures can appear as a result of the substructures from the previous stages being corrected. This approach introduces a regularization to the inverse (ill-posed) problem.

3. Discretization and model reduction of problem (P_ω)

The updating method is developed in a finite element environment which requires to discretize the problem. Large size industrial models lead to costly calculations because problem (P_ω) needs to be solved many times in order to perform model updating. In this section, after detailing the discretization of the problem, we propose a reduction technique in order to lower the costs associated to model updating of large size industrial models.

3.1. Discrete formulation of problem (P_ω)

The discretization of the problem using the finite element method leads to the construction of the stiffness, mass and damping matrices $[\mathbf{K}]$, $[\mathbf{M}]$ and $[\mathbf{B}]$ as well as the vectors of nodal values of fields \underline{U} , \underline{V} and \underline{W} , which will be designated by $\{U\}$, $\{V\}$ and $\{W\}$. The discrete form of the modified error is

$$e_\omega^2(\{U\}, \{V\}, \{W\}) = \frac{\gamma}{2} \{U - V\}^* [[\mathbf{K}] + T\omega^2[\mathbf{B}]] \{U - V\} + \frac{1-\gamma}{2} \{U - W\}^* \omega^2[\mathbf{M}] \{U - W\} + \frac{r}{1-r} \{\Pi U - \tilde{U}_\omega\}^* [\mathbf{G}_r] \{\Pi U - \tilde{U}_\omega\}. \quad (21)$$

Here, matrix $[\mathbf{G}_r]$ represents the error measure $\|\cdot\|^2$. The choice of that error measure is not critical and, for example, one can take

$$[\mathbf{G}_r] = \frac{\gamma}{2} [([\mathbf{K}]_r + T\omega^2[\mathbf{B}]_r)] + \frac{1-\gamma}{2} \omega^2[\mathbf{M}]_r \quad (22)$$

where $[\mathbf{K}]_r$, $[\mathbf{M}]_r$ and $[\mathbf{B}]_r$ are the reduced stiffness, mass and damping matrices of the system at the measurement locations (the classical Guyan reduction can be used). Other approaches exist but this simple approach has given satisfactory results in the past. The triplet $s = (\{U\}, \{V\}, \{W\})$ must be admissible, which means that must satisfy the equilibrium equations:

$$[[\mathbf{K}] + i\omega[\mathbf{B}]]\{V\} - \omega^2[\mathbf{M}]\{W\} = \{F\}. \quad (23)$$

$\{F\}$ represents the excitation and is equal to zero in the case of free vibration. e_ω^2 can be minimized under the admissibility constraint by introducing Lagrange multipliers, which leads to a saddle-point problem. One can show that problem (P_ω) requires the resolution of the following system of linear equations:

$$[A]\{X\} = \{B\} \quad (24)$$

with

$$[A] = \begin{bmatrix} \frac{\gamma}{2}([\mathbf{K}] + T\omega^2[\mathbf{B}]) & \frac{1-\gamma}{2}\omega^2[\mathbf{M}] & \frac{r}{1-r}\Pi^T[\mathbf{G}_r]\Pi \\ \frac{\gamma}{2}([\mathbf{K}] + T\omega^2[\mathbf{B}]) & \frac{1-\gamma}{2}([\mathbf{K}] - i\omega[\mathbf{B}]) & 0 \\ ([\mathbf{K}] + i\omega[\mathbf{B}]) & -\omega^2[\mathbf{M}] & (-[\mathbf{K}] - i\omega[\mathbf{B}] + \omega^2[\mathbf{M}]) \end{bmatrix}, \quad (25)$$

$$\{X\} = \begin{bmatrix} \{U - V\} \\ \{U - W\} \\ \{U\} \end{bmatrix}, \quad (26)$$

$$\{B\} = \begin{bmatrix} \frac{r}{1-r} \Pi^T [\mathbf{G}_r] \{\tilde{U}_\omega\} \\ 0 \\ \{F\} \end{bmatrix}. \quad (27)$$

3.2. Forced-vibration aspect of the problem

The second set of equations allows us to express $\{U - W\}$ as a function of $\{U - V\}$:

$$\{U - W\} = -\frac{\gamma}{1-\gamma} ([\mathbf{K}] - i\omega[\mathbf{B}])^{-1} ([\mathbf{K}] + T\omega^2[\mathbf{B}]) \{U - V\}. \quad (28)$$

3.2.1. Approximation

We assume that the operator $i\omega[\mathbf{B}]$ is small compared to the stiffness (this is the case if the damping or the frequency is small), which allows us to perform a reduced-order development of operator $([\mathbf{K}] - i\omega[\mathbf{B}])^{-1}$, which yields

$$\{U - W\} \simeq -\frac{\gamma}{1-\gamma} \sum_{j=0}^m (i\omega)^j \left(([\mathbf{K}]^{-1}[\mathbf{B}])^j + T\omega^2 ([\mathbf{K}]^{-1}[\mathbf{B}])^{j+1} \right) \{U - V\} = -\frac{\gamma}{1-\gamma} [Z_m] \{U - V\}. \quad (29)$$

The first set of equations in (24) becomes

$$([\mathbf{K}] - \omega^2[\mathbf{M}]) \{U - V\} = \{F_1\} + \{F_2\} + \{F_3\} = \{F\}_T \quad (30)$$

with

$$\begin{aligned} \{F_1\} &= -\frac{2}{\gamma} \frac{r}{1-r} \left(\Pi^T [\mathbf{G}_r] \Pi \{U\} - \tilde{U}_\omega \right), \\ \{F_2\} &= -T\omega^2 [\mathbf{B}] \{U - V\}, \\ \{F_3\} &= -\omega^2 [\mathbf{M}] ([\mathbf{Id}] - [Z_m]) \{U - V\}. \end{aligned}$$

Field $\{U - V\}$ is the solution of an undamped forced vibration problem where the force vector is the sum of three contributions. If we retain only the first-order term of the development ($m = 1$), we get

$$\{F_3\} = T\omega^2 [\mathbf{M}] [\mathbf{K}]^{-1} [\mathbf{B}] \{U - V\}.$$

The third set of equations in (24) becomes

$$([\mathbf{K}] - \omega^2[\mathbf{M}]) \{U\} = \{F\} + \{F_4\} + \{F_5\} \quad (31)$$

with

$$\begin{aligned} \{F\} &\text{ excitation applied to the structure,} \\ \{F_4\} &= -i\omega[\mathbf{B}]\{U\}, \\ \{F_5\} &= \left([\mathbf{K}] + i\omega[\mathbf{B}] + \omega^2 \frac{\gamma}{1-\gamma} [\mathbf{M}] ([\mathbf{Id}] + T\omega^2 [\mathbf{K}]^{-1} [\mathbf{B}]) \right) \{U - V\}. \end{aligned}$$

Field $\{U\}$ is also the solution of a forced vibration problem.

3.2.2. Remark

In the correction step, system (24) is solved many times for different values of the structural parameters. This leads to modifications of matrices $[\mathbf{K}]$, $[\mathbf{M}]$ and $[\mathbf{B}]$ which become respectively $[\mathbf{K} + \Delta\mathbf{K}]$, $[\mathbf{M} + \Delta\mathbf{M}]$ and $[\mathbf{B} + \Delta\mathbf{B}]$. Thus, the forced vibration problems are modified by adding on the right-hand side terms of the form:

$$\{F\}_K = [\Delta\mathbf{K}]\{U\}, \quad (32)$$

$$\{F\}_M = [\Delta\mathbf{M}]\{U\}, \quad (33)$$

$$\{F\}_B = [\Delta\mathbf{B}]\{U\}. \quad (34)$$

3.3. Reduced bases for the resolution of problem (P_ω)

3.3.1. Generalities

For large industrial models, the direct calculation of the solution of problem (P_ω) can be very costly. Although the system is linear, its size is $3N \times 3N$, N being the number of degrees of freedom of the model. An alternative is to use a reduced basis consisting of the so-called Ritz vectors. Let $[\mathbf{T}]$ be that reduced basis; we define the following reduced quantities (identified by the subscript r):

$$\{U\} = [\mathbf{T}]\{U\}_r, \quad (35)$$

$$\{U - V\} = [\mathbf{T}]\{U - V\}_r, \quad (36)$$

$$\{U - W\} = [\mathbf{T}]\{U - W\}_r, \quad (37)$$

$$\{F\}_r = [\mathbf{T}]^T\{F\}, \quad (38)$$

$$[\mathbf{K}]_r = [\mathbf{T}]^T[\mathbf{K}][\mathbf{T}], \quad (39)$$

$$[\mathbf{M}]_r = [\mathbf{T}]^T[\mathbf{M}][\mathbf{T}], \quad (40)$$

$$[\mathbf{B}]_r = [\mathbf{T}]^T[\mathbf{B}][\mathbf{T}], \quad (41)$$

$$\Pi_r = \Pi[\mathbf{T}]. \quad (42)$$

Now, the system to be solved is $3NR \times 3NR$, NR being the number of vectors in the reduced basis $[\mathbf{T}]$. Note that choosing the same basis for $\{U\}$, $\{U - V\}$ and $\{U - W\}$ is not necessarily optimal. It has the advantage however to lower the number of reduced operators to compute.

3.3.2. Choice of the reduced basis

At a given frequency ω , we consider the undamped forced vibrations problem in its discrete form:

$$([\mathbf{K}] - \omega^2[\mathbf{M}])\{U\} = \{F\}. \quad (43)$$

Let $\{\Phi_j\}$ and ω_j be an eigenmode and the associated eigenfrequency. They verify the equation

$$([\mathbf{K}] - \omega_j^2[\mathbf{M}])\{\Phi_j\} = \{0\}. \quad (44)$$

For a system with N degrees of freedom, there are N pairs $(\{\Phi_j\}, \omega_j)$ which verify this equation. A classical approach to the construction of a reduced basis is to consider a reduced set of such vectors. A truncated modal basis is built by taking L eigenmodes such that

$$\frac{\omega}{\omega_i} \ll 1, \quad i > L. \quad (45)$$

In order to improve the approximation, a series of vectors, commonly called the Krylov vectors associated with the excitation $\{F\}$, is added to the basis. These vectors take the form:

$$[\mathbf{K}]^{-1}([\mathbf{M}][\mathbf{K}]^{-1})^j \{F\}, \quad j = 1, \dots, H. \quad (46)$$

A justification can be found, for example, in [24] (where the method is called modal acceleration method). The first term of this series is the static response of the structure to the given excitation $\{F\}$. The next terms are static responses to forces $([\mathbf{M}][\mathbf{K}]^{-1})^j \{F\}$. One can show that the contribution of the terms in the Krylov series decreases if condition (45) is verified. This explains why a very good approximation of the solution can be obtained by simply adding the static response of the structure to the L selected eigenmodes.

3.3.3. Application to problem (P_ω)

3.3.3.1. *Calculation of $\{U - V\}$.* Let us first note that the static response to $\{F_3\}$ corresponds to the second vector of the Krylov series associated with $\{F_2\}$. Thus, the Krylov vectors associated with $\{F_2\}$ are sufficient to represent the excitation $\{F_3\}$.

3.3.3.2. *Approximation of the excitations.* The vector $\{F_1\}$ is a function of $\{U\}$ which is solution of the problem and, therefore, unknown. One can see that the components of $\{F_1\}$ are zero except for the measured degrees of freedom. Thus, this force can be considered as the sum of unit forces ($\{F_1\}_i$) at each of the NS sensors:

$$\{F_1\} = \sum_{i=1}^{NS} a_i \{F_1\}_i. \quad (47)$$

$\{F_2\}$ is a function of $\{U - V\}$, which is also unknown. However, $\{U - V\}$ can be approximated by

$$\{U - V\} = [\mathbf{T}]_0 \{U - V\}_r \quad (48)$$

with

$$[\mathbf{T}]_0 = \left[\{\Phi\}_1 \cdots \{\Phi\}_L [\mathbf{K}]^{-1} \{F_1\}_1 \cdots [\mathbf{K}]^{-1} \{F_1\}_{NS} \right]. \quad (49)$$

Thus, $\{F_2\}$ can be expressed as

$$\{F_2\} = [\mathbf{B}] \left[\sum_{i=1}^L a_i \{\Phi_i\} + \sum_{i=1}^{NS} b_i [\mathbf{K}]^{-1} \{F_1\}_i \right]. \quad (50)$$

The second term in this expression represents a correction to the first. In order to simplify the expression of $\{F_2\}$, we consider only

$$\{F_2\} = \sum_{i=1}^L a_i [\mathbf{B}] \{\Phi_i\}. \quad (51)$$

This approach is very similar to the one presented in [20] and to basis initialization methods considered in [21] and the correction proposed in [18].

3.3.3.3. *Calculation of $\{U\}$.* Following the same approach we used for the approximation of $\{F_2\}$, we show that

$$\{F_4\} = \sum_{i=1}^L a_i [\mathbf{B}] \{\Phi_i\} = \{F_2\}. \quad (52)$$

$\{F_5\}$ can be decomposed into four contributions:

$$\begin{aligned} & [\mathbf{K}]\{U - V\}, \\ & [\mathbf{M}]\{U - V\}, \\ & i\omega[\mathbf{B}]\{U - V\}, \\ & [\mathbf{M}][\mathbf{K}]^{-1}[\mathbf{B}]\{U - V\}. \end{aligned}$$

The first two contributions do not lead to a correction since the terms $[\mathbf{K}]\{\Phi_i\}$ and $[\mathbf{M}]\{\Phi_i\}$ excite only mode $\{\Phi_i\}$. The fourth contribution is the second Krylov vector of the third contribution and, thus, can also be disregarded. The third contribution leads to the same terms as in the case of $\{F_2\}$.

3.3.3.4. *Correction.* For the correction step, using the same approach, we get the following approximations:

$$\{F\}_K = \sum_{i=1}^H b_i[\Delta\mathbf{K}]\{\Phi_i\}, \quad (53)$$

$$\{F\}_M = \sum_{i=1}^H c_i[\Delta\mathbf{M}]\{\Phi_i\}, \quad (54)$$

$$\{F\}_B = \sum_{i=1}^H d_i[\Delta\mathbf{B}]\{\Phi_i\}. \quad (55)$$

3.4. Summary

We have shown that problem (P_ω) can be expressed as an undamped forced vibration problem for the different fields considered in the calculation of the error. The excitations can be approximated by a linear combination of the forces:

- $\{F\}$, vector of the excitations applied to the structure;
- $\{F_1\}_i$, unit force at sensor i ;
- $\{F_2\}_i = [\mathbf{B}]\{\Phi_i\}$, $i = 1, \dots, L$, associated with damping;
- $\{F\}_{Ki} = [\Delta\mathbf{K}]\{\Phi_i\}$, $i = 1, \dots, L$, associated with variations of the stiffness parameters;
- $\{F\}_{Mi} = [\Delta\mathbf{M}]\{\Phi_i\}$, $i = 1, \dots, L$, associated with variations of the mass parameters;
- $\{F\}_{Bi} = [\Delta\mathbf{B}]\{\Phi_i\}$, $i = 1, \dots, L$, associated with variations of the damping parameters.

These excitations are associated with the less reliable experimental measurements (intensity of the excitation and amplitudes at the sensors), with damping and with the less reliable equations of the numerical model (mass, stiffness and damping parameters of the constitutive relations). The reduced basis contains the first L eigenmodes as well as the Krylov vectors associated with each excitation.

3.5. Practical considerations in building the reduced bases

The environment used for the implementation of the method consists of the MATLAB program [25] and the SDT toolbox [26]. The numerous options of the toolbox allow us to calculate the eigenmodes and frequencies, assemble the elementary and global stiffness, mass and damping matrices and calculate the static responses to the excitations. The reduced matrices constructed with these vectors are usually ill-conditioned because some vectors are very nearly collinear. Therefore, it is necessary to orthonormalize the

reduced basis. This is achieved using a Lanczos-type algorithm with SVD (singular value decomposition) (`fe_norm` function in SDT) in order to obtain a well-conditioned problem. In the course of applying this function, certain vectors can be eliminated.

4. Numerical applications

4.1. Presentation of the structure

The structure studied is shown in Fig. 2(a)

It is a simplified model of camera equipment intended to be attached to an airplane. The finite element model has 10,008 dofs. It is divided into 18 substructures identified by different levels of grey. Three modifications were applied to the initial model prior to simulating the measurements (Fig. 2(b)):

- a +20% stiffness increase at the bindings (in black, $\Delta K1$);
- a -40% stiffness reduction at the connection ring (in grey, $\Delta K2$);
- a -20% error on the mass at the tip of the equipment (in light grey, ΔM).

4.2. Application 1: modal data

With the modified model, 10 modes were calculated using the finite element model. The sensor configuration, shown on Fig. 3, consisted of 27 triaxial sensors totalling 81 measured accelerations.

4.2.1. Localization step

The methodology presented in the case of the damped FRFs can be applied to the modal data by taking $\{F\} = 0$ and $[\mathbf{B}] = 0$, i.e. $\{F_2\}_i = 0$. The only excitation left is $\{F_1\}$, which is a linear combination of unit forces located at the sensors (81 locations in this case).

The localization step was carried out using the following three bases:

- *Basis 1*: first 100 eigenmodes of the nominal structure;
- *Basis 2*: first 10 eigenmodes + static responses to $\{F_1\}_i$, $i = 1, \dots, 81$ (first term of the Krylov series);
- *Basis 3*: Basis 2 + second term of the Krylov series associated with $\{F_1\}_i$ ($i = 1, \dots, 81$).

A reference calculation was carried out using the full model. The local indicators are compared in Fig. 4.

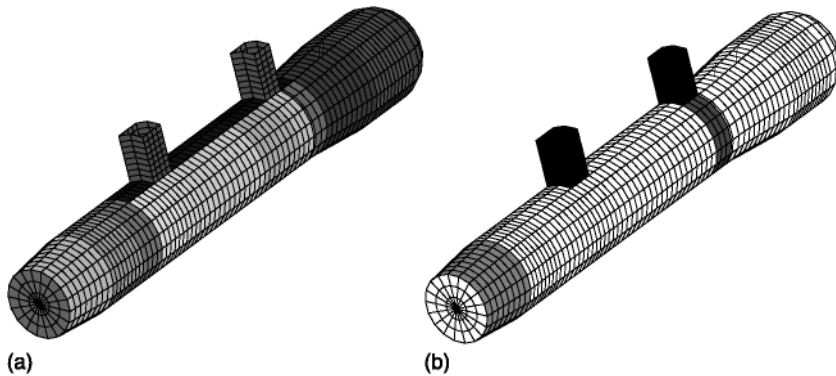

Fig. 2. Simplified model of camera equipment: (a) finite element model and (b) modifications.

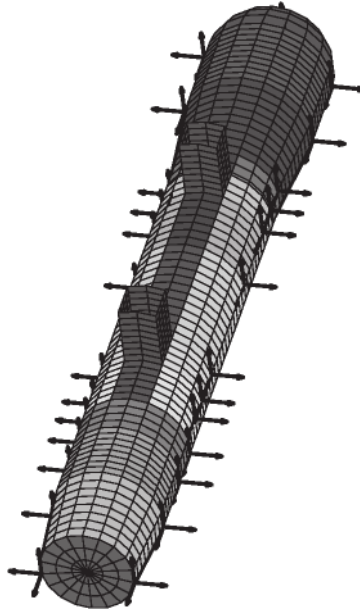

Fig. 3. Sensor configuration of the test structure.

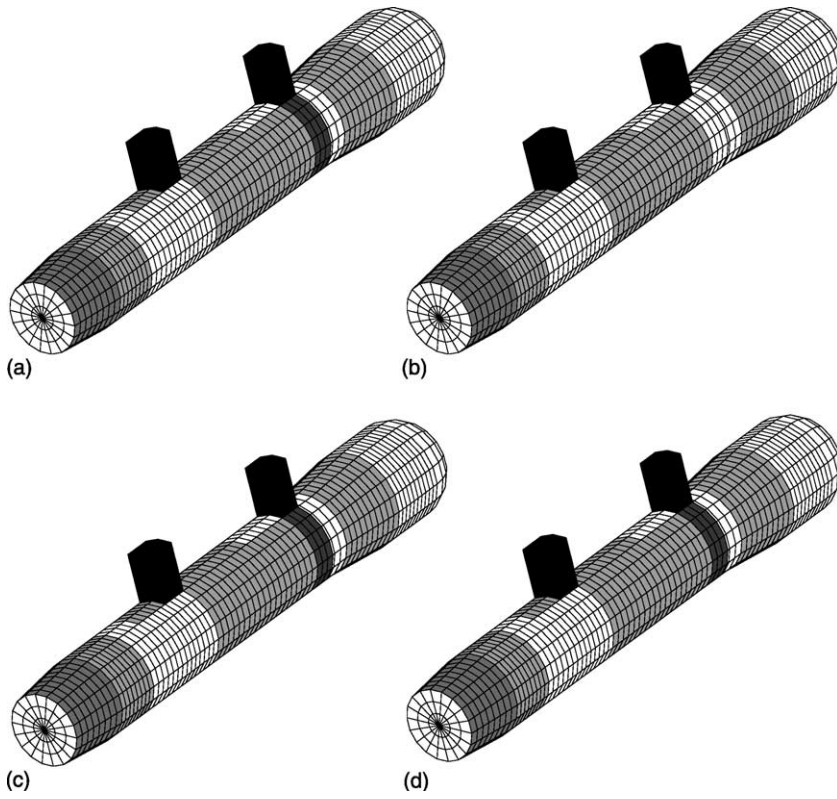

Fig. 4. Location indicators: (a) reference calculation, (b) Basis 1, (c) Basis 2, and (d) Basis 3.

The location indicators show that Bases 2 and 3 gave the correct location of the modifications according to the reference calculation. On the contrary, Basis 1, which uses only the eigenmodes of the nominal structure, failed to detect the modification on the connection ring.

The global error ξ_T^2 was 6.079% for the reference calculation and 6.12%, 6.10% and 6.079% for the 10 eigenmodes and Bases 1, 2 and 3 respectively. Although the error level was well-represented by all three bases, the location indicator gave poor results for Basis 1. Basis 3 gave no improvement of the results compared to Basis 2, which means that the first term of the Krylov series is usually sufficient. Thus, we retained only the first term of the series from there on.

4.2.2. Correction step

In order to verify the effectiveness of the proposed bases, we assumed that the erroneous parameters were known. We had two stiffness parameters and one mass parameter. Since no measurement noise was added, we could expect the minimization process to converge toward the exact value of the known modifications introduced in the model. Thus, we performed the correction with the previous three bases.

As proposed, we also added the static response to vectors $\{F\}_{Ki}$ and $\{F\}_{Mi}$ for the three parameters retained in the minimization. Thus, we defined two new bases:

- *Basis 4*: first 20 eigenmodes + static responses to F_{Ki} and F_{Mi} ($i = 1, \dots, 20$);
- *Basis 5*: Basis 4 + static responses to $\{F_1\}_i$, $i = 1, \dots, 81$.

The results are shown in Table 1.

Table 1

	e_{T0} (%)	e_{T1} (%)	$\Delta K1$ (%)	$\Delta K2$ (%)	ΔM (%)	size (T)
Basis 1	8.16	5.23	+19	-60	-20	100
Basis 2	6.32	0.56	+19	-47	-20	91
Basis 3	6.29	0.44	+19	-46	-20	172
Basis 4	7.94	0.29	+20	-40	-20	80
Basis 5	6.29	0.03	+20	-40	-20	161
Exact value	-	-	+20	-40	-20	10 008

e_{T0} and e_{T1} represent the values of the total modified error for the first 10 modes before and after correction. The last column of the table shows the number of vectors retained in the reduced bases. Bases 1–3 do not contain the vectors associated with mass and stiffness variations. Therefore, they yielded a poor correction of the stiffness parameter $\Delta K2$, which is the parameter which did not show up in the localization step with Basis 1. On the other hand, Bases 4 and 5 produced values which were very close to the exact values for all the parameters. The absence of vectors associated with the sensors in Basis 4 resulted in a slight overestimation of the initial error. The results show that the most important vectors for the correction step are those associated with F_{Ki} and F_{Mi} .

Although it is preferable to retain the vectors associated with $\{F_1\}_i$ in the basis, these results show that they are not always needed for the correction step. Therefore, they can be skipped if this reduces the computation costs significantly.

This example illustrates the effectiveness of the reduction method proposed here. For the localization step, we have shown the importance of using the static responses to unit forces at each sensor. For the correction step, we have shown the importance of including the vectors associated with the variations of the parameters to be updated. A reduced basis taking all these vectors into account can be used in both steps. If this basis is too large, a different basis can be used for each of the steps and the localization step can be used to build the reduced basis for the correction step.

4.3. Application 2: Frequency response functions

We considered the same structure as in Application 1 excited with a shaker as shown in Fig. 5(a). The sensor configuration was the same as that in Fig. 3. A nonproportional viscous damping model was used, which means that each elementary damping matrix can be written:

$$[\mathbf{B}]_E = \alpha[\mathbf{K}]_E. \quad (56)$$

Note that the updating method can be used with any kind of damping (hysteretic, fractional derivatives based model, ...). We considered three regions:

- the main structure (Fig. 5(b), in white), coefficient α_0 ;
- Ring 1 (Fig. 5(b), in black), coefficient α_1 ;
- Ring 2 (Fig. 5(b), in black), coefficient α_2 .

The initial values of the damping coefficients are $\alpha_0 = 10^{-10}$, $\alpha_1 = 10^{-6}$ and $\alpha_2 = 10^{-6}$. We assumed that the mass and stiffness properties were perfectly known. The measurements were simulated from the initial model with the following modifications to the damping coefficients: $\alpha_1 = 10^{-2}$, $\alpha_2 = 10^{-2}$.

The transfer functions for the initial and modified models and for the sensor located near, and in the direction of, the excitation are plotted in Fig. 6.

4.3.1. Localization step

We focused on the frequency range (15–30) Hz and we considered 10 regularly spaced frequencies in that interval. The reduced bases were

- *Basis 1*: first 100 eigenmodes of the structure;
- *Basis 2*: first 20 eigenmodes + static responses to $\{F_1\}_i$ ($i = 1, \dots, 81$) and $\{F\}$;
- *Basis 3*: Basis 2 + static responses to $\{F_2\}_i$ ($i = 1, \dots, 20$).

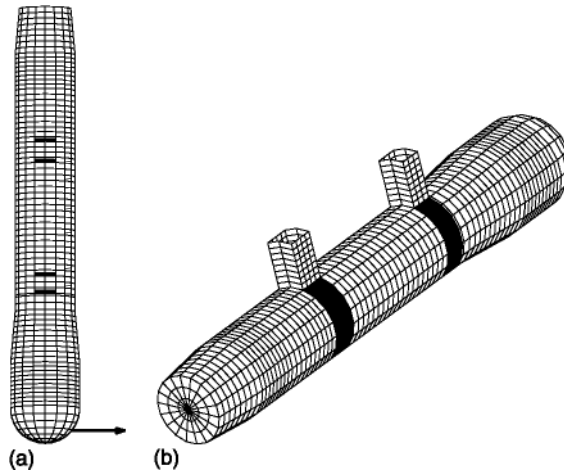

Fig. 5. Excitation (a) and definition of damping distribution (b).

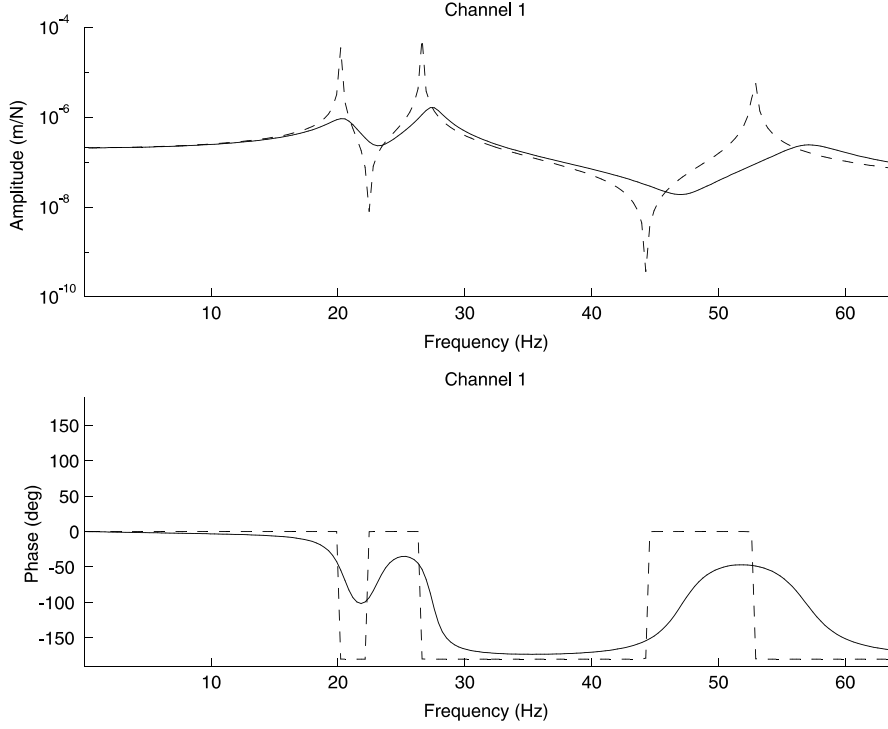

Fig. 6. Measured transfer functions (—) and initial model (- - -).

The values of the location indicator are given in Fig. 7. Basis 1 did not enable us to localize the damping errors correctly. Bases 2 and 3 gave very similar results and allowed us to localize the damping errors. In this case, there was no need to add the vectors associated with $\{F_2\}_i$, which can be explained by the fact that in the initial model damping is very small. We will show that these vectors were necessary in the correction step, in which the correction leads to a model with larger nonproportional damping.

4.3.2. Correction step

Like in the previous example, we corrected the model by acting on only the erroneous parameters of the model in order to see whether we would converge toward the exact known modifications. For the three bases considered, the algorithm converged toward the values given in Table 2. Table 2 shows that Basis 1 gave very poor values of the damping parameters for the updated model. Basis 3 gave the best results, which shows the importance of the vectors associated with $\{F_2\}_i$.

This application, like the previous one, shows the importance of the static responses to $\{F_1\}_i$ and $\{F\}$ for the localization and the importance of the vectors associated with $\{F_2\}_i$ when damping is nonproportional.

Table 2

	e_{T0} (%)	e_{T1} (%)	α_1	α_2	size (T)
Basis 1	27.36	23.95	2.25	0.03	100
Basis 2	36.91	1.78	0.0078	0.0076	102
Basis 3	16.34	0.19	0.0099	0.0101	142
Exact value			0.01	0.01	10 008

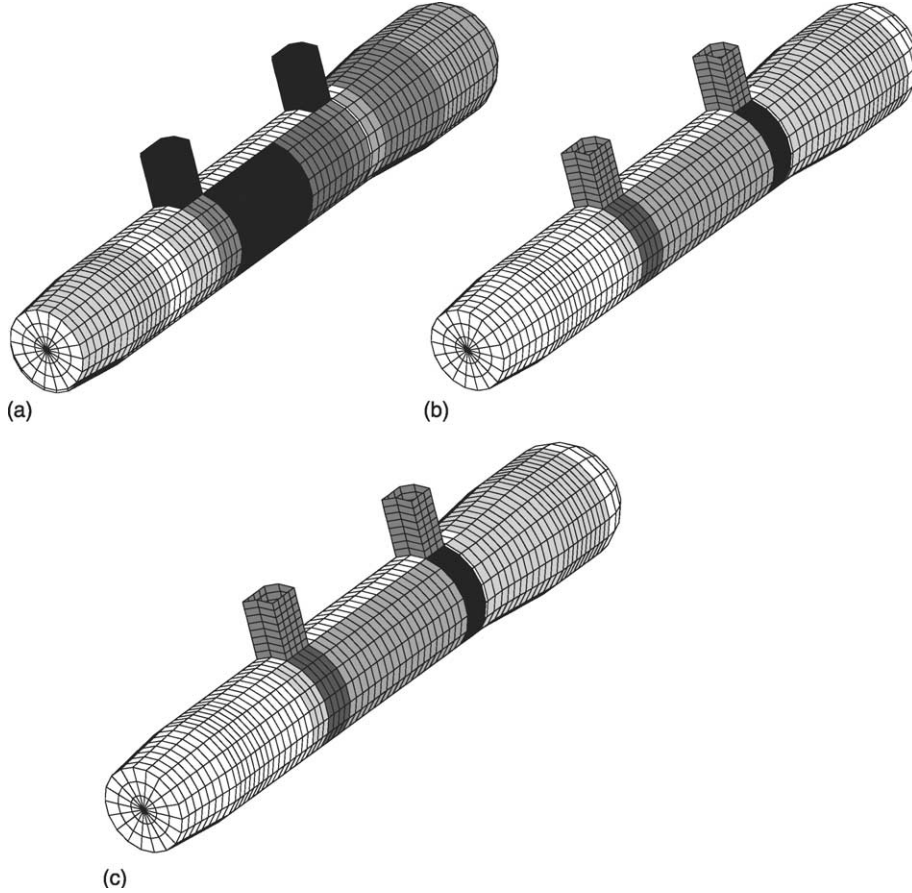

Fig. 7. Location indicators: (a) Basis 1, (b) Basis 2 and (c) Basis 3.

Let us note that the vectors associated with $\{F_2\}_i$ are, in this case, similar to those associated with $\{F\}_{Bi}$, which shows the effectiveness of the proposed reduced basis for the correction step.

5. Conclusion

In this paper, we discussed the problem of how to reduce computing costs in performing model updating based on the error in constitutive relation on large industrial models with several hundreds of thousands of degrees of freedom.

We showed that the calculation of the modified CRE relation can be treated as a forced vibration problem. We also showed that, under certain assumptions, the excitations can be approximated by a linear combination of a set of well-defined excitations.

The reduced bases we used contains the first eigenmodes of the structure as well as the static responses to forces associated with the less reliable quantities in the model, i.e. the parameters in the constitutive relations and the uncertainties on the experimental quantities.

The application of this methodology to model updating showed that for a structure in which the number of sensors is significantly less than the number of degrees of freedom (which is the usual case for typical

industrial structures) the static responses associated with the sensors and excitations are sufficient in the localization step. On the other hand, additional vectors associated with the variations of the parameters give very good results in the correction step.

References

- [1] J. Mottershead, M. Friswell, Model updating in structural dynamics: a survey, *Journal of Sound and Vibration* 167 (2) (1993) 347–375.
- [2] M. Baruch, Optimal correction of mass and stiffness matrices using measured modes, *AIAA Journal* 20 (11) (1982) 1623–1626.
- [3] A. Berman, E.J. Nagy, Improvement of a large analytical model using test data, *AIAA Journal* 21 (8) (1983) 1168–1173.
- [4] M. Kaouk, D. Zimmerman, Structural damage assessment using a generalized minimum rank perturbation, *AIAA Journal* 32 (4) (1994) 836–842.
- [5] D. Zimmerman, M. Kaouk, Eigenstructure assignment approach for structural damage detection, *AIAA Journal* 30 (7) (1992) 1848–1855.
- [6] H. Berger, R. Ohayon, L. Quetin, L. Barthe, P. Ladèveze, M. Reynier, Model updating methods in structural dynamics, *La Recherche Aéronautique* 5 (1991) 9–20 (in French).
- [7] C. Farhat, F.M. Hemez, Updating finite element dynamic models using an element-by-element sensitivity methodology, *AIAA Journal* 31 (9) (1993) 1702–1711.
- [8] J. Piranda, G. Lallement, S. Cogan, Parametric correction of finite element models by minimization of an output residual: Improvement of the sensitivity method, in: *Proc. IMAC IX, SEM, Firenze, Italy, 1991*, pp. 363–368.
- [9] S. Lammens, M. Brughmans, J. Leuridan, W. Heylen, P. Sas, Application of a FRF based model updating technique for the validation of a finite element models of components of the automotive industry, in: *Proc. Design Engineering Technical Conferences, ASME Conferences, Boston, 1995*, pp. 1191–1200.
- [10] P. Ladèveze, Model updating of complex structures, *Tech. Rep. 33.11.01.4, Aéronautique, Les Mureaux, 1983* (in French).
- [11] P. Ladèveze, M. Reynier, A localization method of stiffness errors for the adjustment of FE models, in: *Vibrations Analysis Techniques and Applications, Chap. “FE Modeling and Analysis”, ASME publishers, 1989*, pp. 355–361.
- [12] P. Ladèveze, Error in the constitutive relations in structural dynamics theory and application to model updating, *Internal Report 150, LMT, Cachan, 1993* (in French).
- [13] P. Ladèveze, M. Reynier, N. Maia, Error on the constitutive relation in dynamics, in: H.D. Bui, M. Tanaka, et al. (Eds.), *Inverse Problems in Engineering, 1st ed., Balkema, Rotterdam, 1994*, pp. 251–256.
- [14] P. Ladèveze, A. Chouaki, A modelling error estimator for dynamic model updating of damped structures, in: M. Tanaka, G.S. Dulikravich (Eds.), *Inverse Problems in Engineering Mechanics, Elsevier, London, 1998*, pp. 187–196.
- [15] A. Chouaki, A. Deraemaeker, P. Ladèveze, S. Le Loch, Model updating using the error in the constitutive relation: Real case study, in: *Proc. IMAC XVIII, SEM, San Antonio, Texas, 2000*, pp. 140–146.
- [16] E. Balmès, Review and evaluation of shape expansion methods, in: *Proc. IMAC XVIII, SEM, San Antonio, Texas, 2000*.
- [17] R. Pascual, J.C. Golinval, M. Razeto, On the reliability of error localization indicators, in: *Proc. ISMA 23, Leuven, Belgium, 1998*, pp. 1119–1127.
- [18] E. Balmès, Efficient Sensitivity analysis based on finite element model reduction, in: *Proc. IMAC XVII, SEM, Santa Barbara, CA, 1998*.
- [19] E. Balmès, Parametric families of reduced finite element models. theory and applications, *Mechanical Systems and Signal Processing* 10 (4) (1996) 381–394.
- [20] A. Bouazzouni, G. Lallement, S. Cogan, Selecting a ritz basis for the reanalysis of the frequency response functions of modified structures, *Journal of Sound and Vibration* 2 (1997) 309–322.
- [21] A. Bobillot, E. Balmès, Solving minimum dynamic Residual expansion and using results for error localisation, in: *Proc. IMAC XIX, SEM, Kissimee, Florida, 2001*.
- [22] P. Ladèveze, A. Chouaki, Application of a posteriori error estimation for structural model updating, *Inverse Problems* 15 (1999) 49–58.
- [23] A. Chouaki, P. Ladèveze, L. Proslie, Updating structural dynamic models with emphasis on the damping properties, *AIAA Journal* 36 (6) (1998) 1094–1099.
- [24] Z. Qu, Accurate methods for frequency responses and their sensitivities of proportionally damped systems, *Computers & Structures* 79 (2001) 87–96.
- [25] The Matworks, Matlab Version 5.3.1.
- [26] E. Balmès, Structural Dynamics Toolbox 4.0 (for use with Matlab), International Technologies. Available from <http://www.sdtools.com>.